

GAS FLANGE TO SUIT
STACK SIZE, TYP. TOP
AND BOTTOM.

4" NDM. - 300#
MANIFOLD FLG.
TYP. 2 PLCS.

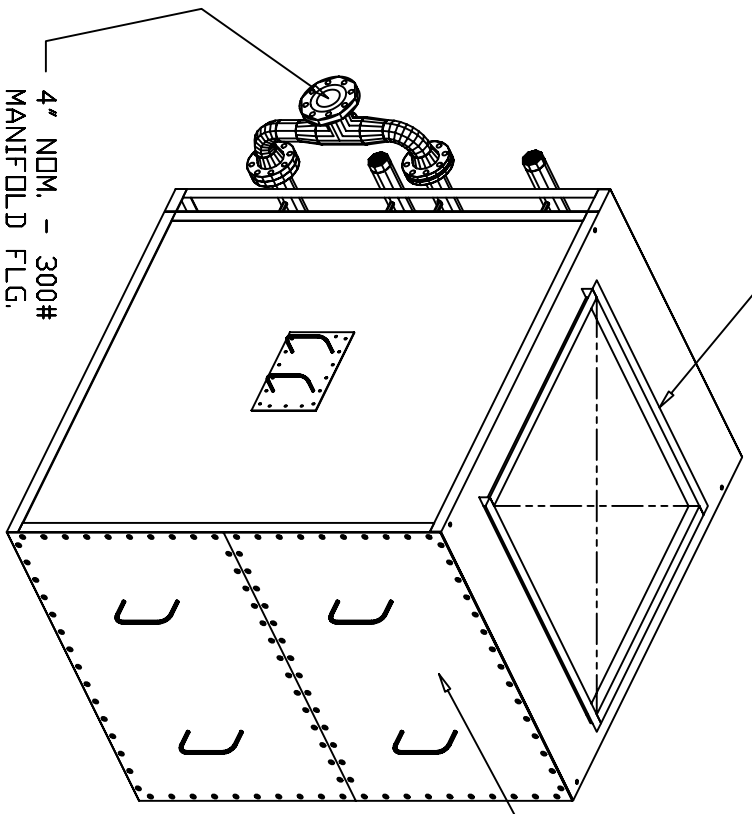

REMOVABLE REAR END
DOOR FOR INSPECTION
AND TUBE REPLACEMENT.

REAR ISOMETRIC VIEW

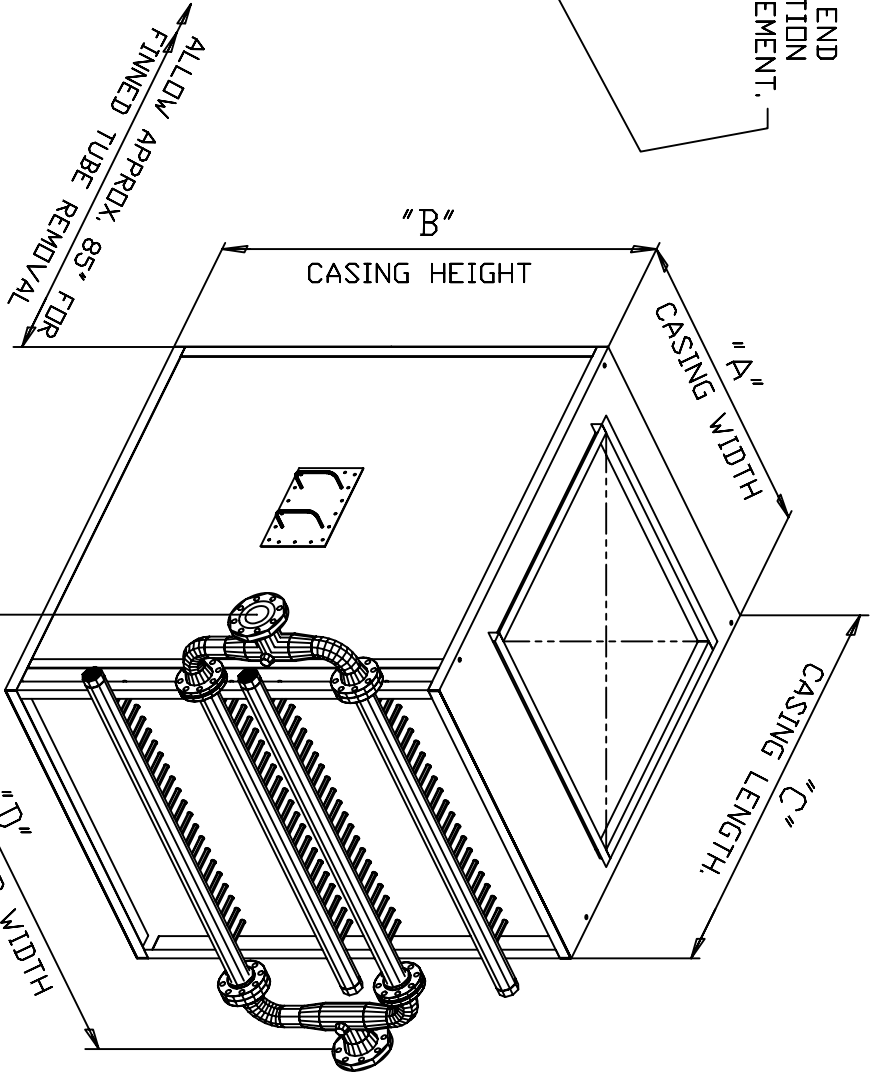

FRONT ISOMETRIC VIEW

DIMENSION TABLE

DIMENSION TABLE

MODEL	"A"	"B"	"C"	"D"	WEIGHT	MODEL	"A"	"B"	"C"	"D"	WEIGHT
HST-12	37 1/4"	81 1/4"	79"	80 1/4"	5000#	HST-25	73"	81 1/4"	79"	116"	7600#
HST-13	40"	81 1/4"	79"	83"	5200#	HST-26	75 3/4"	81 1/4"	79"	118 3/4"	7800#
HST-14	42 3/4"	81 1/4"	79"	85 3/4"	5400#	HST-27	78 1/2"	81 1/4"	79"	121 1/2"	8000#
HST-15	45 1/2"	81 1/4"	79"	88 1/2"	5600#	HST-28	81 1/4"	81 1/4"	79"	124 1/4"	8200#
HST-16	48 1/4"	81 1/4"	79"	91 1/4"	5800#	HST-29	84"	81 1/4"	79"	127"	8400#
HST-17	51"	81 1/4"	79"	94"	6000#	HST-30	86 3/4"	81 1/4"	79"	129 3/4"	8600#
HST-18	53 3/4"	81 1/4"	79"	96 3/4"	6200#	HST-31	89 1/2"	81 1/4"	79"	132 1/2"	8800#
HST-19	56 1/2"	81 1/4"	79"	99 1/2"	6400#	HST-32	92 1/4"	81 1/4"	79"	135 1/4"	9000#
HST-20	59 1/4"	81 1/4"	79"	102 1/4"	6600#	HST-33	95"	81 1/4"	79"	138"	9200#
HST-21	62"	81 1/4"	79"	105"	6800#	HST-34	97 3/4"	81 1/4"	79"	140 3/4"	9400#
HST-22	64 3/4"	81 1/4"	79"	107 3/4"	7000#	HST-35	100 1/2"	81 1/4"	79"	143 1/2"	9600#
HST-23	67 1/2"	81 1/4"	79"	110 1/2"	7200#	HST-36	103 1/4"	81 1/4"	79"	146 1/4"	9800#
HST-24	70 1/4"	81 1/4"	79"	113 1/4"	7400#						



BOILERROOM EQUIPMENT, INC.

TITAN HEATSPONGE

GENERAL ARRANGEMENT

(STANDARD MODELS)

DRAWN BY:	DATE COMPLETE:	REV:
AJH	12/7/06	
SCALE:	JOB NUMBER:	DRAWING NUMBER:
NTS	STD	D-HST-TITAN-GA
		0